

Installation Guide for Gravel Stop

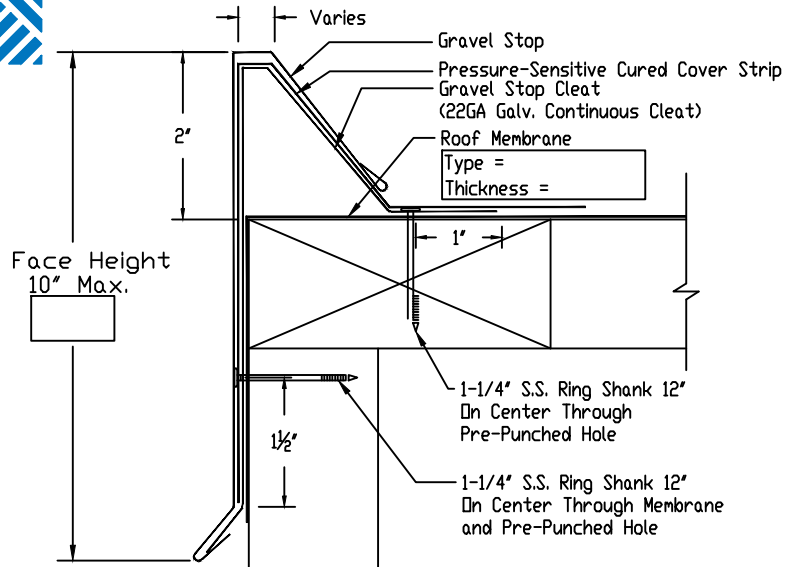

NOTES:
#1 - Isolate all metal parts from ACQ treated wood or other galvanically incompatible material with appropriate membrane material.
#2 - Appliance attachments, such as lightning rods, signs, or antennae that penetrate the water seal, induce a galvanic reaction, or otherwise compromise the effectiveness of the roof edge system, shall be eliminated or isolated to prevent problems per section 8.0 if ANSI/SPRI ES-1. Appliances should also be isolated from, or not attached to, the roof edge system. Consult the lightning protection system manufacturer for specific attachment instructions.

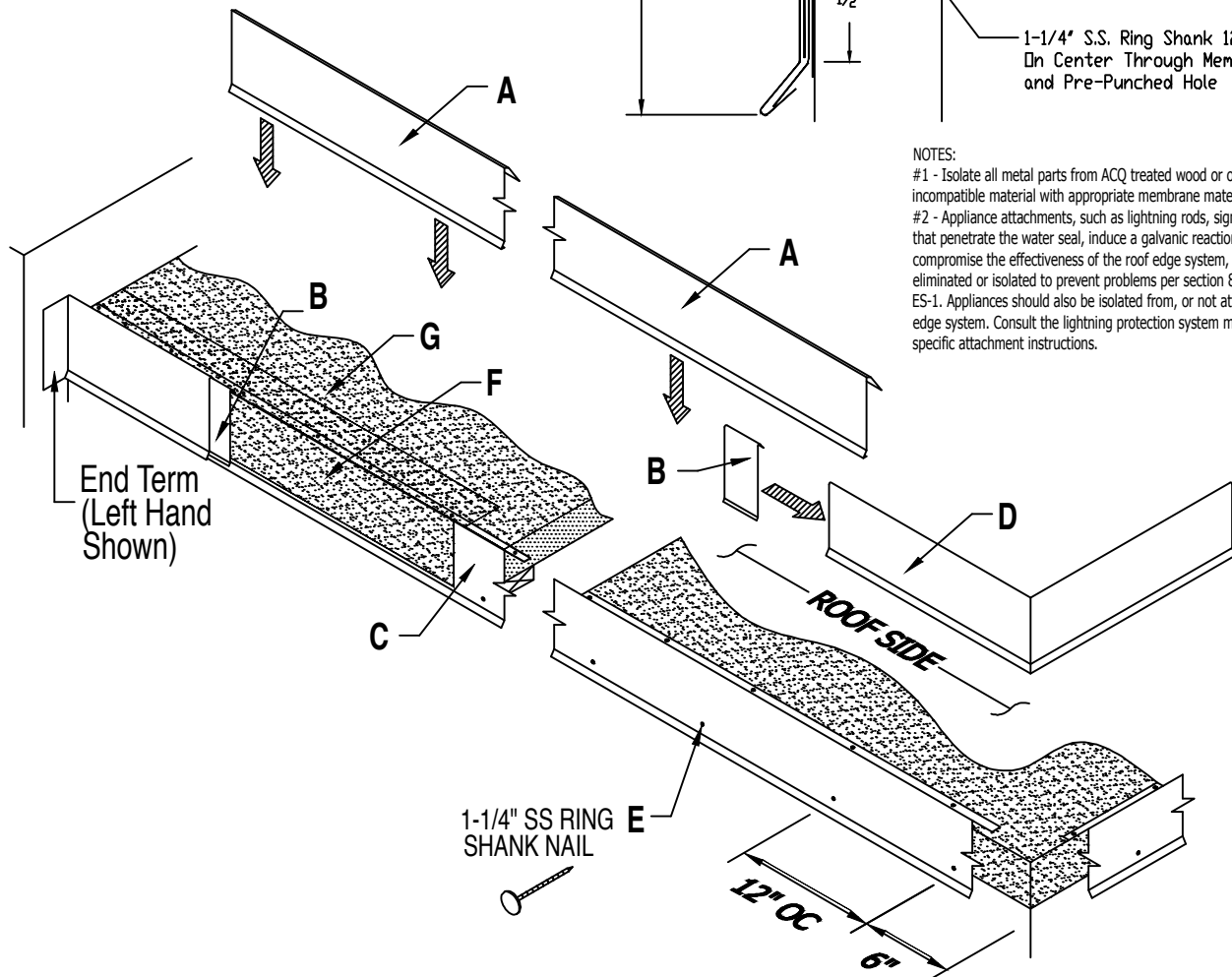

A. Gravel Stop
10'-0" Std. Lengths (20'-0" Max.)

B. Splice Plate
6" Lengths

C. 22GA Galvanized Continuous Cleat
10'-0" Lengths

D. SecurEdge 400 Gravel Stop Miter
(Outside Corner Shown)

E. 1-1/4" S.S. Ring Shank Nail
at 12" o.c. (6" from ends)
(Included & Required)

F. Pressure-Sensitive Cured Cover Strip
(By Installer)

G. Approved Roofing Membrane
(By Installer)

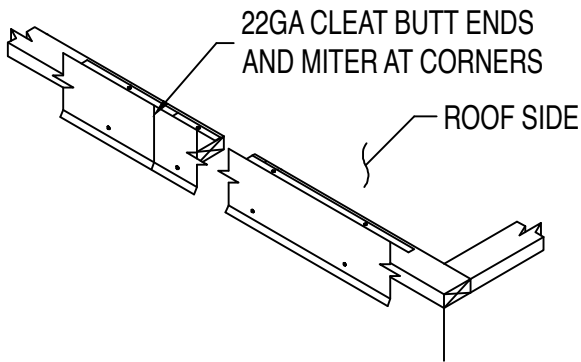

STEP 1 : Installing 22GA Galvanized Cleat

Place the roof side foot of the Cleat squarely on the top edge of the treated wood nailing plate. Press cleats securely in position and nail through the pre-punched holes with 1-1/4" S.S. Ring Shank Nails provided. For Miter application, miter cut into corner as required to maintain a continuous Cleat line. Then nail at a min. 6" in each direction from the corner or closer at special conditions.

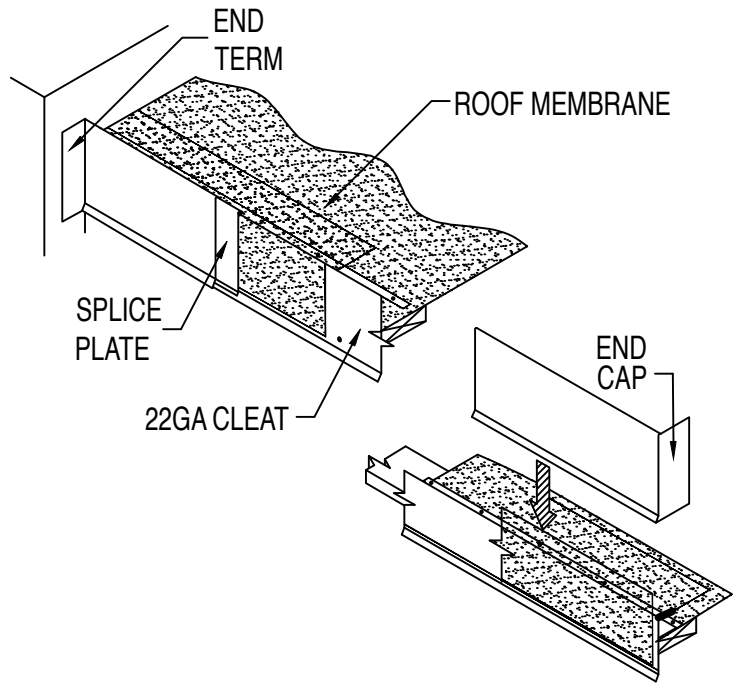

STEP 4 : Installing Gravel Stop End Caps and End Terms

Install the Gravel Stop End Caps and End Terms by placing them over the Cleat, and pushing them down onto the kick out of the Cleat.

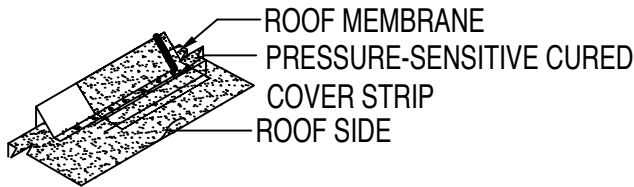

STEP 2 : Installing Pressure-Sensitive Cured Cover Strip

Apply Pressure-Sensitive Cured Cover Strip to cant of 22GA Cleat and down Cleat face per roofing membrane Manufacturer's installation details.

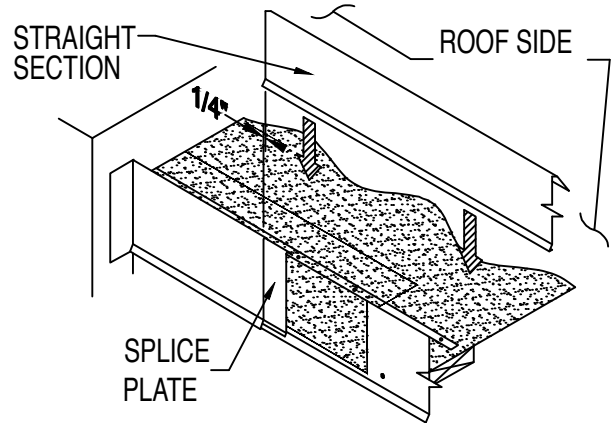

STEP 5 : Installing Gravel Stop Straight Lengths

Place a Splice Plate in the opposite end of the installed Miter or End Cap. Install the Gravel Stop by placing the Gravel Stop over the Cleat, and pushing down the Gravel Stop onto the kick out of the Cleat. **Allow 1/4" Gap between Gravel Stop lengths for thermal expansion.**

Consider lengths of all straight pieces prior to cutting to avoid creating relatively short sections adjacent to one another.

Note: There should be a Splice Plate at every joint.

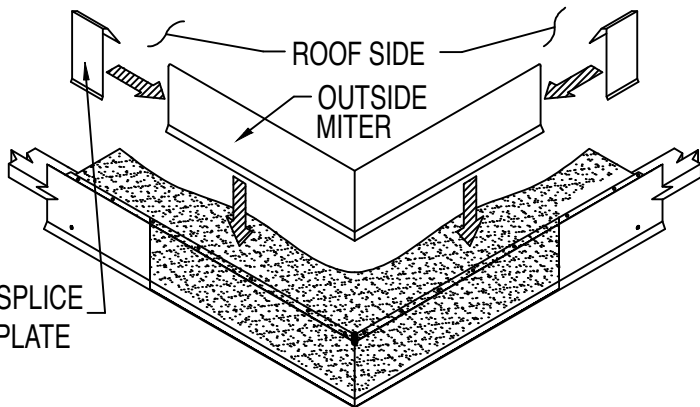

STEP 3 : Installing Gravel Stop Miters

Locate the Miters and Splice Plates for the appropriate corners. Place a Splice Plate under each end of the Miter sections. Install the Miter by placing the Miter over the Cleat, and pushing down the Gravel Stop Miter onto the kick out of the Cleat.