

FASCIA EXTENDER PRINT APPROVAL

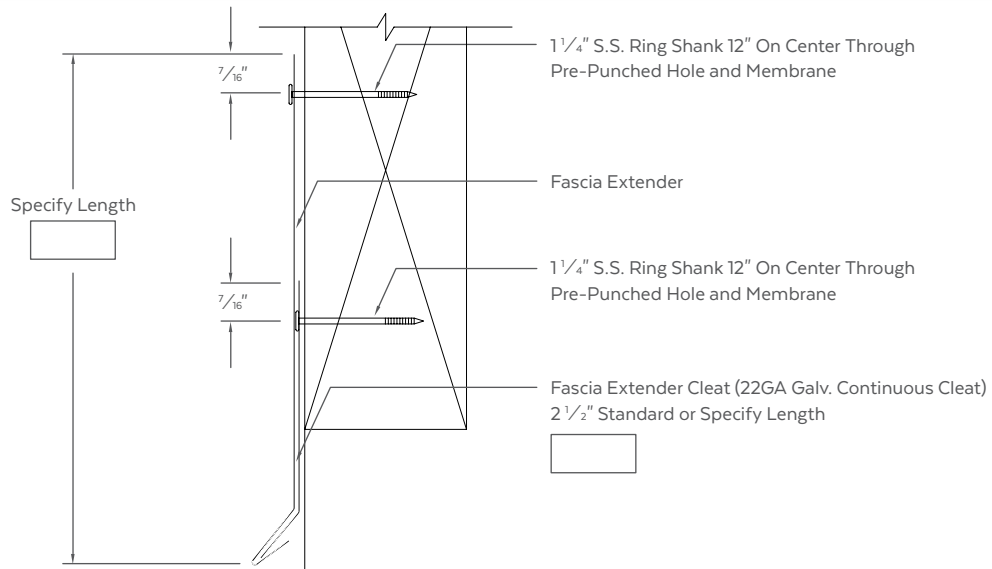

MATERIAL

24GA .040" AL
 22GA .050" AL
 Other: .063" AL

Finish: _____
 Color: _____

QUANTITIES

Lineal Feet (10'-0" Lengths): _____

Outside Miters*: _____ Optional Welded (Surcharge Applies)
 Inside Miters*: _____ Optional Welded (Surcharge Applies)
 Right End Caps*: _____ Optional Welded (Surcharge Applies)
 Left End Caps*: _____ Optional Welded (Surcharge Applies)

* Standard riveted

PROJECT DETAILS

Project: _____
 Architect: _____
 Roofing Contractor: _____
 Representative: _____

PRINT APPROVAL

Architect and/or Contractor shall verify all dimensions, sizes, and quantities, All products to be installed in strict accordance with Drexel's printed instructions.

Effective Date: _____
 Drawn By: _____
 Approved By: _____