

# Installation Guide for Snap Coping-Max/Max-C

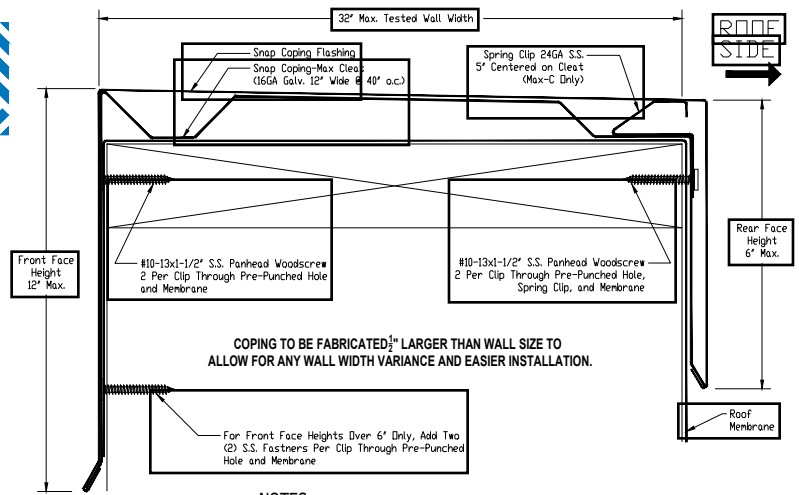

**NOTES:**

- #1 - Isolate all metal parts from ACQ treated wood or other galvanically incompatible material with appropriate membrane material.
- #2 - Appliance attachments, such as lightning rods, signs, or antennae that penetrate the water seal, induce a galvanic reaction, or otherwise compromise the effectiveness of the roof edge system, shall be eliminated or isolated to prevent problems per section 8.0 if ANSI/SPRI ES-1. Appliances should also be isolated from, or not attached to, the roof edge system. Consult the lightning protection system manufacturer for specific attachment instructions.

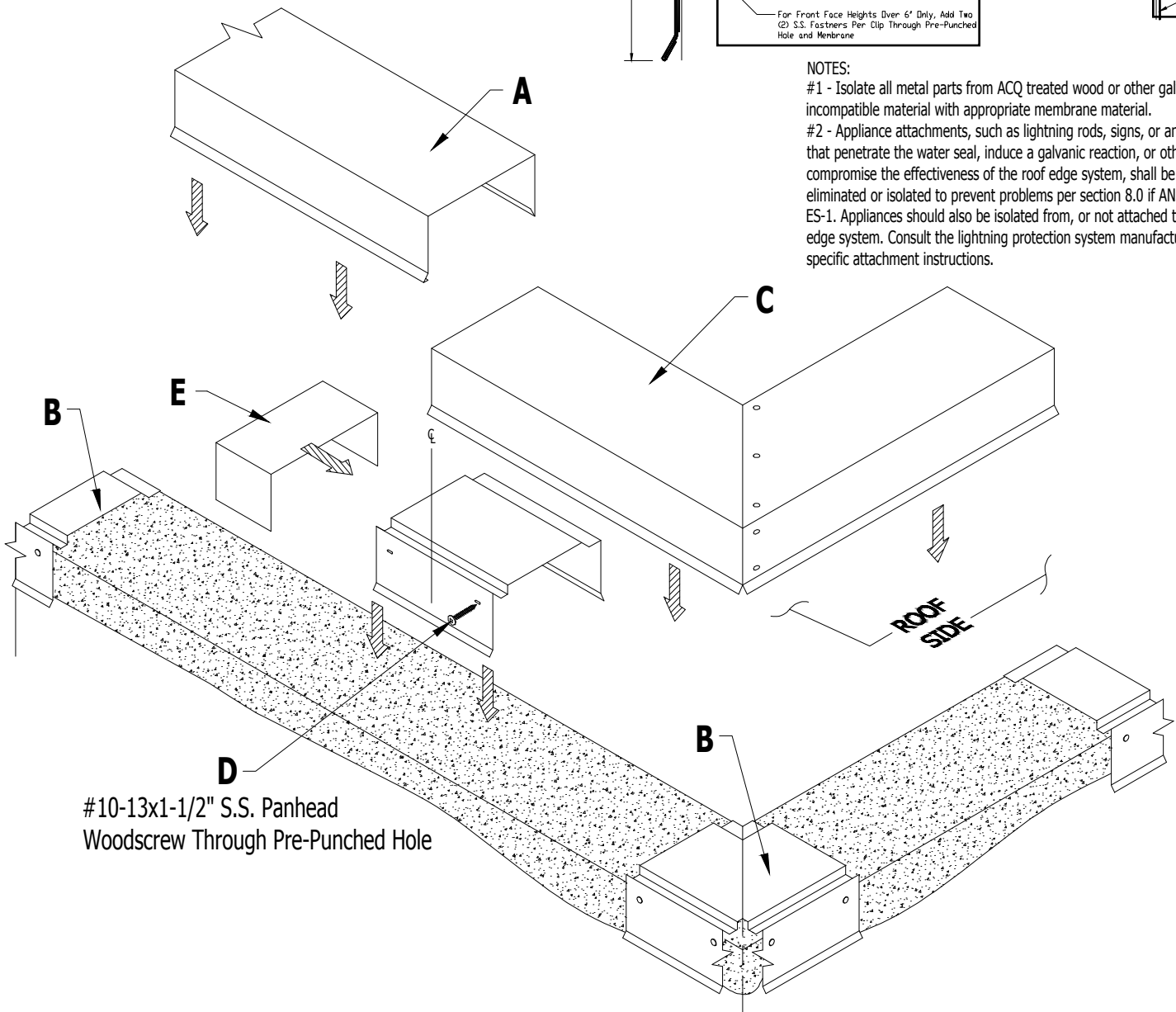

**A. Snap Coping Flashing**  
10'-0" Std. Lengths

**B. 16GA Galvanized Segmented Cleat**  
12" Width, Spaced 40" o.c. MAX.

**C. Snap Coping Miter Cap**  
(Outside Corner Shown)

**D. #10-13x1-1/2" S.S. Panhead Woodscrew**  
Every Pre-Punched Hole  
(Included and Required)

**E. Snap Coping Splice Plate**  
6" Length (Installed over Cleat)

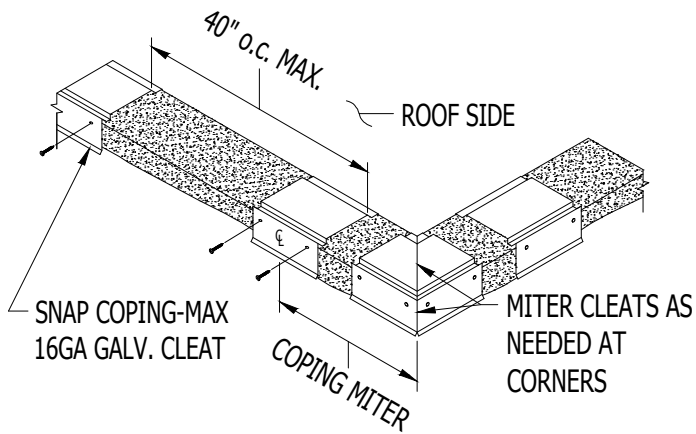

**OUTSIDE CORNER**

**STEP 1: Installing Segmented Galvanized Cleat**

Prior to installing the Cleat, ensure that all metal components have been isolated from ACQ treated lumber with appropriate membrane material. Miter cut Cleats together as needed at corner conditions. Install first Cleat, working away from corner Cleat, so half of the first Cleat will be under Miter. Additional Cleats to be installed no greater than 40" on center. Attach the Cleat using #10-13x1-1/2" S.S. Panhead Woodscrews provided into each pre-punched hole.

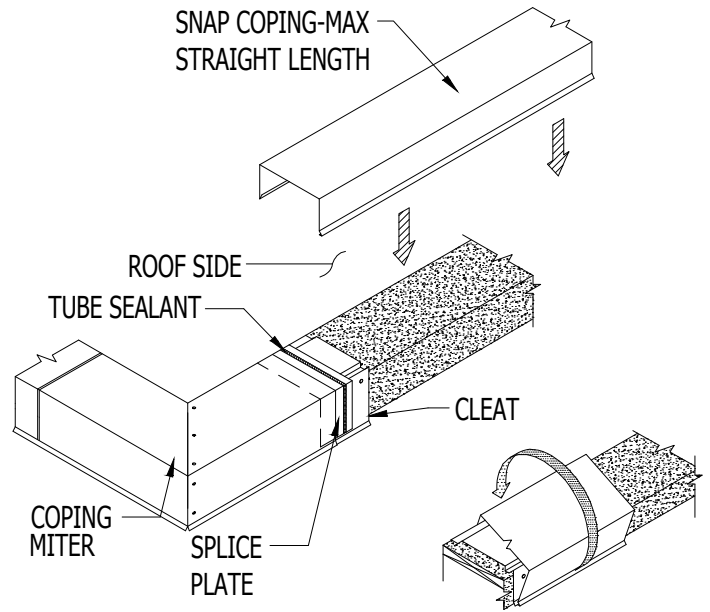

**STEP 3: Installing Snap Coping-Max Straight Lengths**

Make sure the Cleats line up centered with the ends of the coping flashing. Apply a bead of Tube Sealant over the Splice Plate. Hook the front face of the coping flashing over the front kick of the Cleats, then rotate the coping flashing over the top of the parapet and push down the rear face of the coping flashing over the rear Cleat face to engage the rear kick. Consider lengths of all straight pieces prior to cutting to avoid creating relatively short sections adjacent to one another.

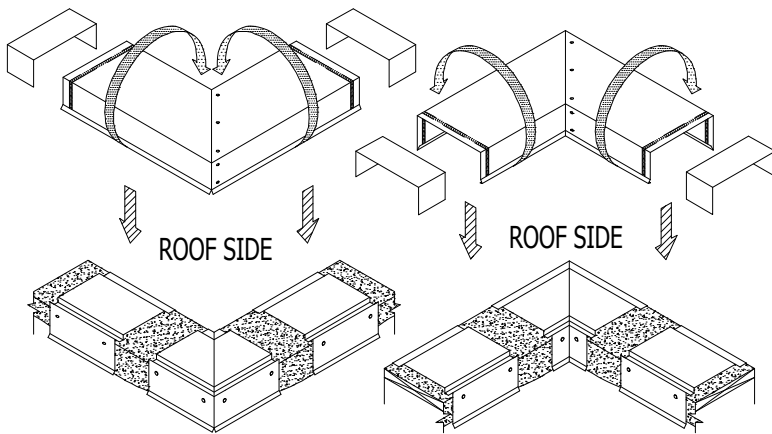

**OUTSIDE CORNER**

**INSIDE CORNER**

**STEP 2: Installing Snap Coping-Max Mitters**

Locate the Miter for the appropriate corner. Make sure the Cleats line up centered with the ends of the Miter. Apply a bead of Tube Sealant inside each end of the Miter. Install a Splice Plate into each end of the Miter. Hook the front face of the Miter over the front kick of the Cleat, then rotate the Miter over the top of the parapet and push down the rear face of the Miter over the rear face of the Cleat to engage the rear kick.

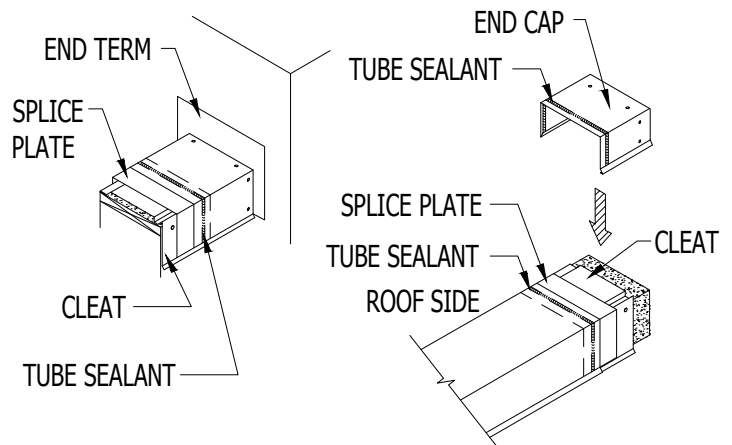

**STEP 4: Installing Snap Coping-Max End Caps/Terms**

Pop-rivet the End Cap and End Term inserts into place. Apply a bead of Tube Sealant and install a Splice Plate into the End Term or End Cap. Install End Caps and End Terms by hooking the front drip over the front kick out on the Cleat and rotating over the part over the parapet. End Caps and End Terms must be restrained from moving by securing with fasteners through the roof side leg.